

DIAPHRAGM TYPE DIFFERENTIAL GAUGE

PRESSURE GAUGES

REOTEMP Series D40/D42 differential pressure gauges are ideally suited for use on dissimilar fluids, wet gas or fluids with a high concentration of solids. Other applications include: use in Filter/Strainer Monitoring, Compressed Air, Hydraulic, Refrigerant, Pump Performance Testing, Heat Exchanger Pressure Drop Monitoring, Water Treatment Applications, Tank Level Monitoring Horizontal or Vertical, and Flow Monitoring & Balancing.



D40

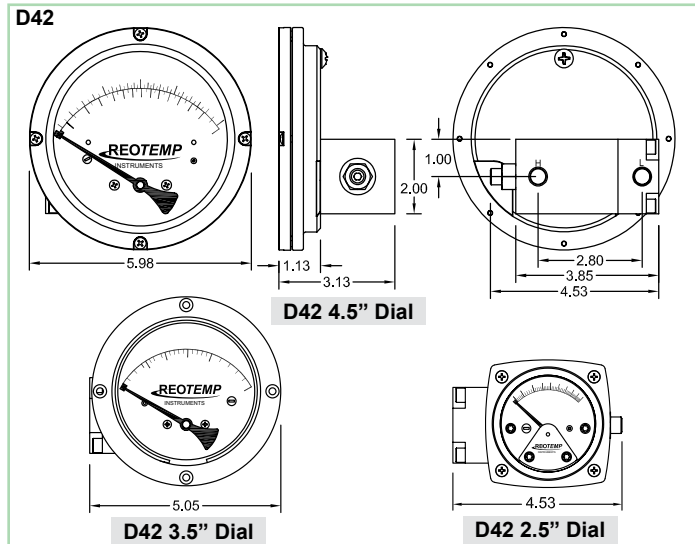
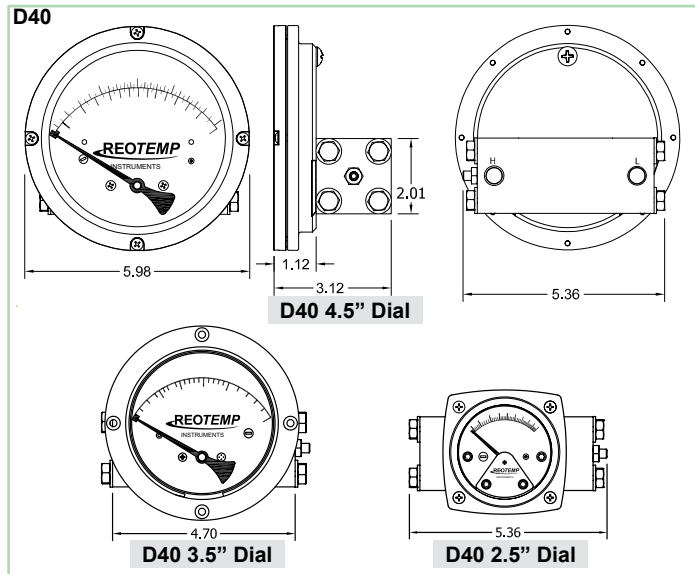

Fillable



Diaphragm Seal
Compatible

FEATURES / BENEFITS

- Total Separation of High and Low by a Convuluted Elastomer Diaphragm
- Liquid Fillable Case Available
- For Use with Diaphragm Seals†
- Weatherproof Rated to NEMA 4X/IP65
- Working Pressure Up to 3,000 psi

SPECIFICATIONS

Accuracy	± 3 - 2 - 3%
Ambient Limits	-40°F/130°F
Process Limits	-40°F/200°F
Process Limits with Diaphragm Seal	-60°F/350°F (Direct Mount)* -110°F/750°F (Remote Mount or Cooling Tower)* *Exact limits depend on diaphragm seal and fill fluids.
Wetted Materials	Body: Aluminum, Brass, Monel, Aluminum-bronze, 316SS Internal Parts: 316SS, Monel Gaskets/Seals: Buna, Viton, Silicone, or Ethylene Propylene
Lens	Plastic (Standard) or Laminated Safety Glass
Other Materials	Case: Aluminum or Engineered Plastic, Dial: White Aluminum, Black Letters
Fillable	Yes, 4.5" Aluminum Case Only
Maximum Working Pressure	3,000 psi (6,000 proof) Aluminum or SS Body, 1,500 psi (3,000 proof) Brass Body
Environmental Protection	NEMA 4X/IP65

†Diaphragm seals protect the gauge against corrosion, heat, and clogging from certain process fluids. Diaphragm seals will reduce accuracy.

DIAPHRAGM TYPE DIFFERENTIAL GAUGE

PRESSURE GAUGES



Visit reotemp.com

- ✓ Configure Part #
- ✓ Generate a Custom Engineering Drawing
- ✓ Get Price
- ✓ Download PDF Data Sheets

HOW TO ORDER: Choose options to build a part number. For example: **D402PAB-B4XXX-PD5-M1**

D40	2P	A	B	-B4	XX	X
SERIES	DIAL SIZE & CASE MATERIAL	BODY/ INTERNALS	DIAPHRAGM & GASKETS	PROCESS CONNECTION	SWITCH TYPE AND HOUSING	ELECTRICAL SPECIFICATION
D40 = For DP Ranges of 30-100 psid D42 = For DP Ranges of 20" inH ₂ O _d thru 25 psid	2P = 2.5" Dial, Plastic Case 4P = 4.5" Dial, Plastic Case 3A = 3.5" Dial Aluminum Case 4A = 4.5" Dial, Aluminum Case	A = Aluminum/316SS S = 316SS/316SS B = Brass/316SS M = Monel/316SS N = Aluminum-bronze/316SS <div style="background-color: #e0e0e0; padding: 2px; text-align: center;">Wetted</div>	B = Buna-N V = Viton S = Silicone E = Ethylene Propylene <div style="background-color: #e0e0e0; padding: 2px; text-align: center;">Wetted</div>	-B4 = 1/4" NPTF back -T4 = 1/4" NPTF top -L4 = 1/4" NPTF bottom -E4 = 1/4" NPTF end connection -E2 = 1/2" NPTF end adapters	XX = None A1 = Single reed switch, NEMA4X enclosure A2 = Dual reed switch, NEMA4X enclosure D1 = Single reed switch, explosion proof enclosure* D2 = Dual reed switch, explosion proof enclosure* E1 = Single reed switch, NEMA4X/explosion proof enclosure** E2 = Dual reed switch, NEMA4X/explosion proof enclosure** Transmitter Type and Housing: TA = 4-20mA transmitter in NEMA4X enclosure TX = 4-20mA transmitter in explosion proof enclosure**	X = None A = SPDT, 3W, .25Amp B = SPST, 25W, .5Amp 230VAC/Vdc T = 4-20mA output 8-28Vdc loop power

*Complete Assembly Rated Class 1, Div. 1, Groups C&D; Class II, Div. 1, Groups E, F, G
**Complete assembly rated class 1, Div. 2, groups A, B, C, D; Class II, Div. 2, Groups F&G

Diaphragm Seal Suitability Guide

Differential Pressure Gauges are very sensitive and require diaphragm seals with high fluid displacement. If a diaphragm seal is required to isolate the process fluid from the pressure gauge, the following seal model types are available for the Series D40/42.

-PD5	-M1
PRESSURE RANGE	OPTIONS
-PD5 = 0-5 psid -PD10 = 0-10 psid -PD20 = 0-20 psid -PD100 = 0-100 psid -ID25 = 0-25 inH ₂ O _d -ID100 = 0-100 inH ₂ O _d	-M1 = 2" Pipe Mounting Kit with Carbon Steel Bracket -M2 = 2" Pipe Mounting Kit with Stainless Steel Bracket -M3 = Wall Mounting Kit -SG = Laminated Safety Glass (4A Dial ONLY) -MP = Max Pointer (Not Available with SG or LF) -LF = Liquid fill (only with 4A dial, std. lens) -TS = SS tag -OX = Cleaned for oxygen service -C3 = 3pt. Calibration Cert.

For Additional Range Codes See Page 46

Diaphragm Seal Model

Total Gauge Span

		<99"H ₂ O	100"H ₂ O	150"H ₂ O	10psi	15psi	20psi+
High Displacement	W7	X	S	S	T		
	T6	X	X	X	T		
	V5	X	S	T			

	Assembly will function correctly with minimal accuracy degradation.
T	Assembly will function correctly given stable temperature.
S	Assembly is highly sensitive to orientation and temperature variance. REOTEMP cannot guarantee a stated accuracy.
X	Assembly will not work. The diaphragm does not displace enough fill fluid to drive the pressure gauge.

Visit reotemp.com/configurators for easy seal configuration.