

# FRM Flush Ring Model Code

## Model Code

FRM - T1 - T2 - T3 - T4 - T5 - T6 - T7 - T8

### FRM Flush Ring

T1	Instrument Side Flange Connection NPS
34	3/4"
10	1"
15	1-1/2"
20	2"
30	3"
40	4"

T2	Flange Configuration
A	ANSI/ASME raised face
U	Universal
J	Ring type joint

T3	Process Side Flange Connection NPS
34	3/4"
10	1"
15	1-1/2"
20	2"
30	3"
40	4"

T4	Material
S	316/316L stainless steel
L	A350 LF2
H	Hastelloy C276
Other	Consult factory

T5	Rating Class per B16.5
1	Class 150
3	Class 300
6	Class 600

T6	Internal Connection
C	Concentric
Other	Consult factory

T7	Number of Flush Connections
1	Bottom connection
2	Top & bottom connection

T8	Connection Type
SW05	1/2" socket weld
SW75	3/4" socket weld
FT	1/2" NPT
TT	3/4" NPT (bore = 0.913")

## Outline & Dimensions

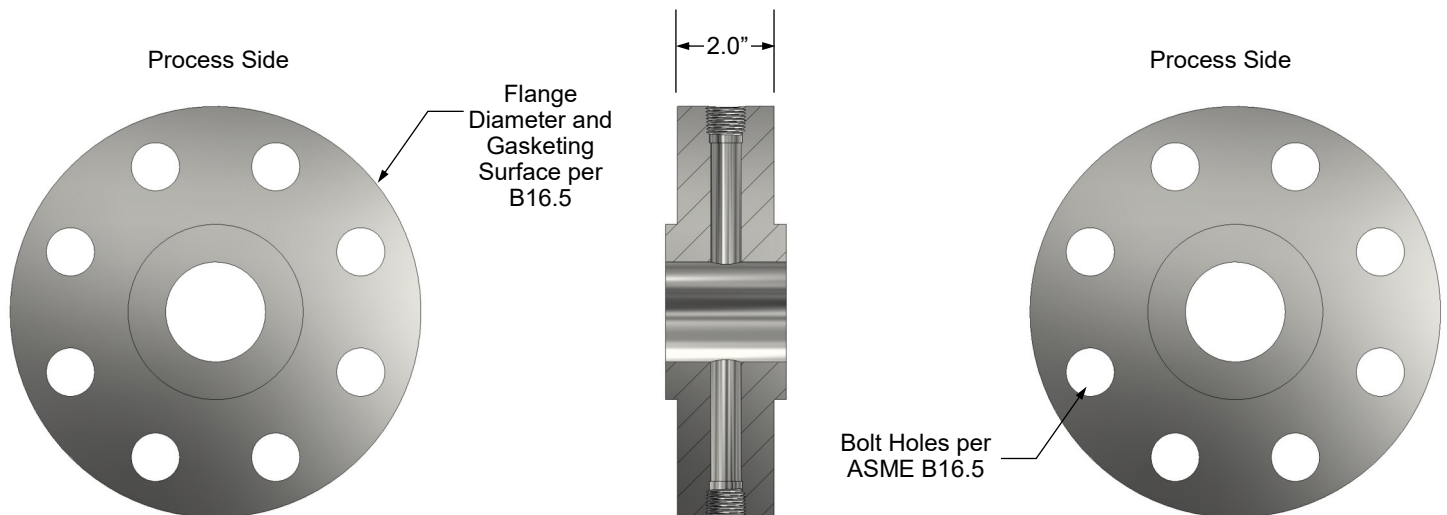

### NOTES:

1. Part number example: FRM-34-A-34-S-3-C-2-TT



Section: Process Piping & Fitting Products  
File: Flush-Ring-FRM-2