

# MG3 Magnet Sensor

## Model Code

MG3 - T1 - T2 - T3 - T4 - T5 - T6

### MG3 Magnet Sensor 150 lbs Holding Force

#### T1 Sensor Probe Style

NGT	90° bend grounded thermocouple
NUT	90° bend ungrounded thermocouple
NCR	90° bend copper tip RTD <sup>3</sup>
NSR	90° bend 316 stainless steel tip RTD
SGT	Straight grounded thermocouple
SUT	Straight ungrounded thermocouple
SCR	Straight copper tip RTD <sup>3</sup>
SSR	Straight 316 stainless steel tip RTD

#### T2 Sensor Type

K	Type K Thermocouple
J	Type J Thermocouple
R3	100Ω Pt. 385 Class A <sup>4</sup> 3-Wire RTD
R4	100Ω Pt. 385 Class A <sup>4</sup> 4-Wire RTD

#### T6 Sensor Probe "X" Length (inches)

"inches"	Specify length - minimum 4.5"
"N" inches"	Specify "N" and length for 90° bend - minimum 5.5"

#### T4 Sensor Probe Construction

LT	Low temperature (-50 to 260°C)
HT	High temperature <sup>4</sup> (-50 to 482°C)
ET	Extreme temperature <sup>4</sup> (-50 to 850°C)
VT	Vibration construction <sup>4</sup> (-50 to 482°C)
CT	Cryogenic temperature (-200 to 260°C)

#### T5 Lead Wire Type

FB	Fiberglass (482°C)
AF	Flex armour over fiberglass (482°C)
TE	Teflon (260°C)
ST	Teflon with SS over braid (260°C)
AT	Flex armour over Teflon (260°C)
PT	Poly jacketed flex armour over Teflon (102°C)
Other	Consult factory

#### T6 Lead Wire "A" Length (inches)

"inches"	Specify length in inches
----------	--------------------------

## Outline & Dimensions

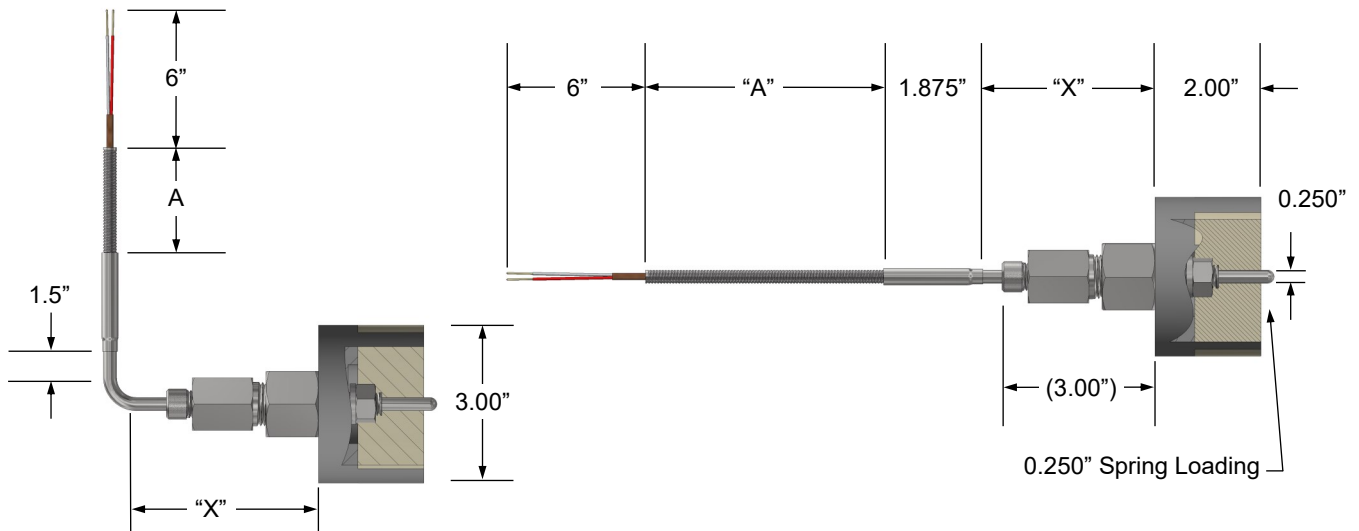

### NOTES:

1. Part number example: MG3-SUT-K-6-LT-AT-24
2. Sensor probes material is 316/316L stainless steel
3. Copper tip RTD probe style is only available with LT and sensor probe construction (T4)
4. Class A tolerance definitions will only be applicable for temperatures under 300°C, Class B tolerance will apply to over 300°C
5. Magnet body packed with ceramic cement insulation
6. Magnet temperature rating -75 to 538°C
7. Adjustable spring tension and removable sensor probes.