

Multipoint Temperature Sensors & Assemblies

Overview

Multipoint temperature sensors and assemblies are constructed using either thermocouple or RTD temperature sensing elements. The temperature sensor points are sheathed for protection from the process or built into a larger assembly.

Multipoint temperature sensors and assemblies are used in industrial process environments where multiple temperature readings are required in a single temperature sensor connection point. They are commonly found in process reactors, catalytic crackers, fractionization towers, vessels and storage tanks. Multipoint's optimize the process by providing temperature profiles across a specific areas of the chemical reaction or process media.

Design Considerations

When designing a multipoint to suit your application it is important to consider the following:

- Process media, temperature and pressure compatibility
- Connection to process
- Multipoint sensor housing or assembly style
- Sensor type (Thermocouple or RTD)
- Number of points and point location
- Insertion length
- Diameter of sensor housing
- Material and compatibility with process
- Transition to lead wire and lead wire type
- Electrical termination

Aircom can integrate an electrical enclosure or junction box with terminal blocks. User defined conduit entries will provide access to end user for termination to the control system. Or in some cases an electrical enclosure is not required and the multipoint is supplied with flying lead wires for further end user termination.

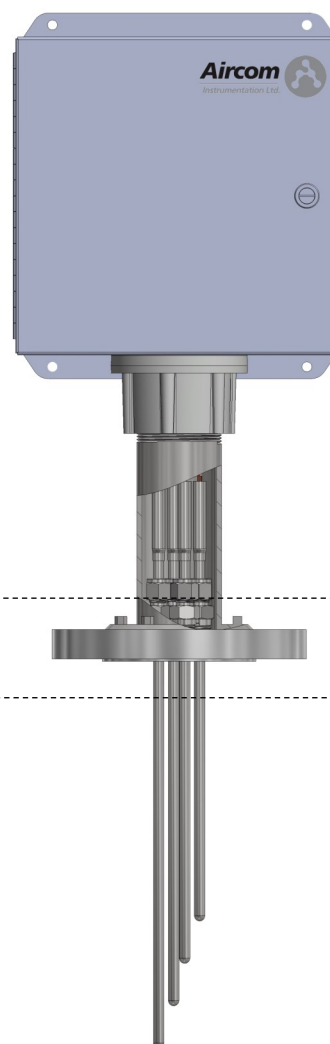

Connection to process is commonly flanged or threaded

The sensor sheathing into the process is commonly constructed from an alloy that extends into the process. It can either flexible or rigid. In some designs sensor points are contained inside an overall sheath similar to a thermowell while other designs integrate the sensor elements into the sheathing wall itself.