

PT1 Silicon Carbide Protection Tube

Model Code

PT1 - T1 - T2

PT1	Silica Carbide Protection Tube
T1	Style
CPT	Mounting collar
SPT	Reducer fitting - 3/4" NPT

T2	Tube "U" Length
12	12"
16	16"
18	18"
24	24"
30	30"
36	36"
42	42"
48	48"

Outline & Dimensions CPT

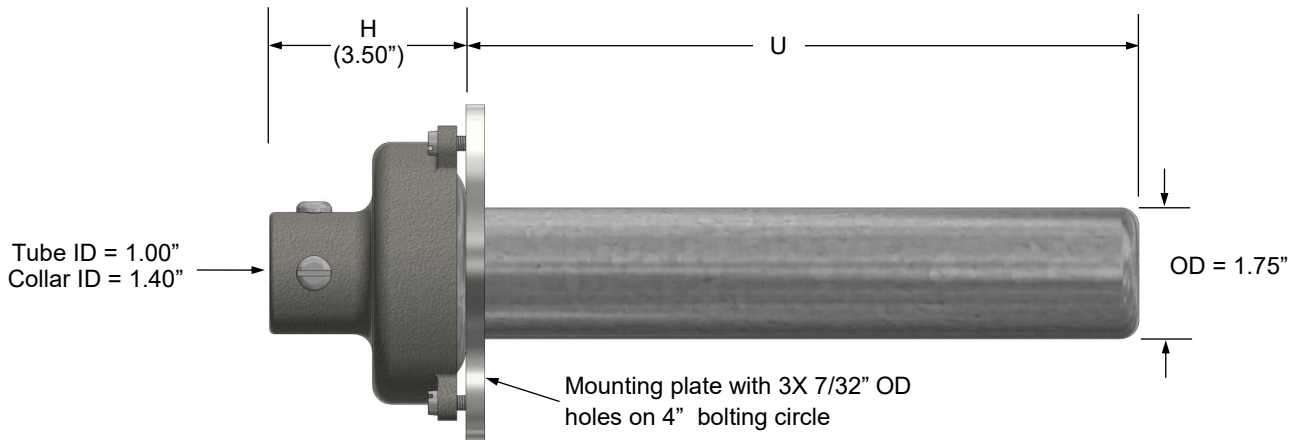

Outline & Dimensions SPT

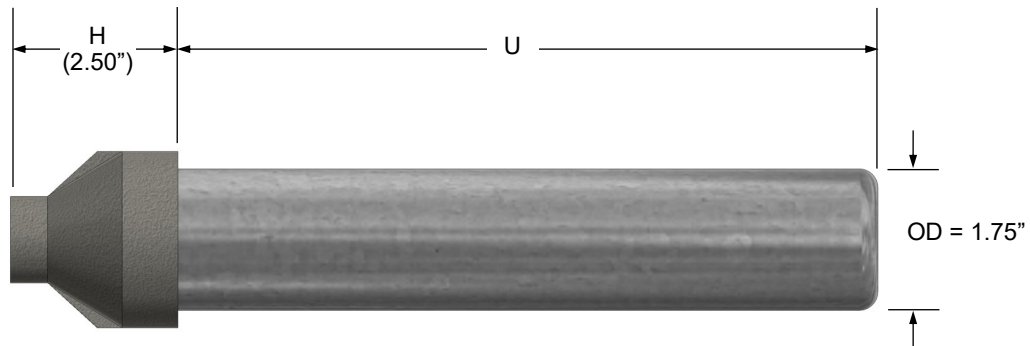

NOTES:

1. Part number example: PT1-CPT-16
2. For thermocouple sensor reference PT2 part configuration. Sensor "L" lengths:
 Style CPT - "L" Length = U + H + 1"
 Style SPT - "L" Length = U + H + 1"