

F227 Straight Flanged Quill Model Code

F227 - T1 - T2 T3 T4 T5 - T6 - T7 - T8 - T9 - T10

F227 Straight - 0.260" Bore - Flanged - Quill

T1	Quill Stem Material		
304	304/304L stainless	F11	F11
316	316/316L stainless	F44	Alloy 254
310	310 stainless steel	F51	Duplex 2205
600	Inconel 600	HAC	Hastelloy C276
625	Inconel 625	HAB	Hastelloy B
800	Incoloy 800	LF2	A350 LF2
825	Incoloy 825	M40	Monel 400
8HT	Incoloy 800 HT	Ti2	Titanium Grade 2
A20	Alloy 20	Other ² Consult factory	
F9	F9		

T2	Flange Size NPS	Nominal Pipe OD
1"	1" NPS	1.315"
1.5"	1.5" NPS	1.900"
2"	2" NPS	2.375"
Other	Consult factory	

T3	Flange Class per ASME B16.5
150#	Class 150
300#	Class 300
600#	Class 600
900#	Class 900
1500#	Class 1500
2500#	Class 2500

T4	Flange Face
RF	Raised face
RTJ	Ring-type joint
FF	Flat face

T5	Quill Flange Material		
304	304/304L stainless	F11	F11
316	316/316L stainless	F44	Alloy 254
310	310 stainless steel	F51	Duplex 2205
600	Inconel 600	HAC	Hastelloy C276
625	Inconel 625	HAB	Hastelloy B
800	Incoloy 800	LF2	A350 LF2
825	Incoloy 825	M40	Monel 400
8HT	Incoloy 800 HT	Ti2	Titanium Grade 2
A20	Alloy 20	Other ² Consult factory	
F9	F9		

T6	Specify "U" Length (inches) ³
"inches"	Specify length in inches

T7	Specify "H" Head Length (inches) ³
2.25	2.25" standard minimum for class 150#, 300#, 600#
3.25	3.25" standard minimum for class 900#, 1500# 2500#
Other	Specify length in inches

T8	Specify "A" & "B" (Shank) Diameter ⁴
0.50	0.5" (minimum)
0.625	0.625"
0.75	0.75" (standard)
1.00	1.00"
1.125	1.125"
1.250	1.250"
1.5	1.5"
Other	Specify outside diameter in inches

T9	Quill Opening
45	45° Angle
90	90° Angle (straight)
HD	Holes along shank ⁵

T10	Process Flow Orientation
G	Into back wall of pipe
L	Into 45° or holes along shank

NOTES:

1. Part number example: F227-316-2"600#RF316-10-2.25-1.063-0.75-45-L
2. Canadian Registration Number (CRN) available for most common alloys, consult factory
3. Reference page 2 for part outline and dimensions
4. Maximum allowable shank diameter must be less than the nominal pipe OD (T2)
5. Specify number of holes, size and locations
6. Bold text indicates most common part selections



F227 Flanged Quill Outline & Dimensions

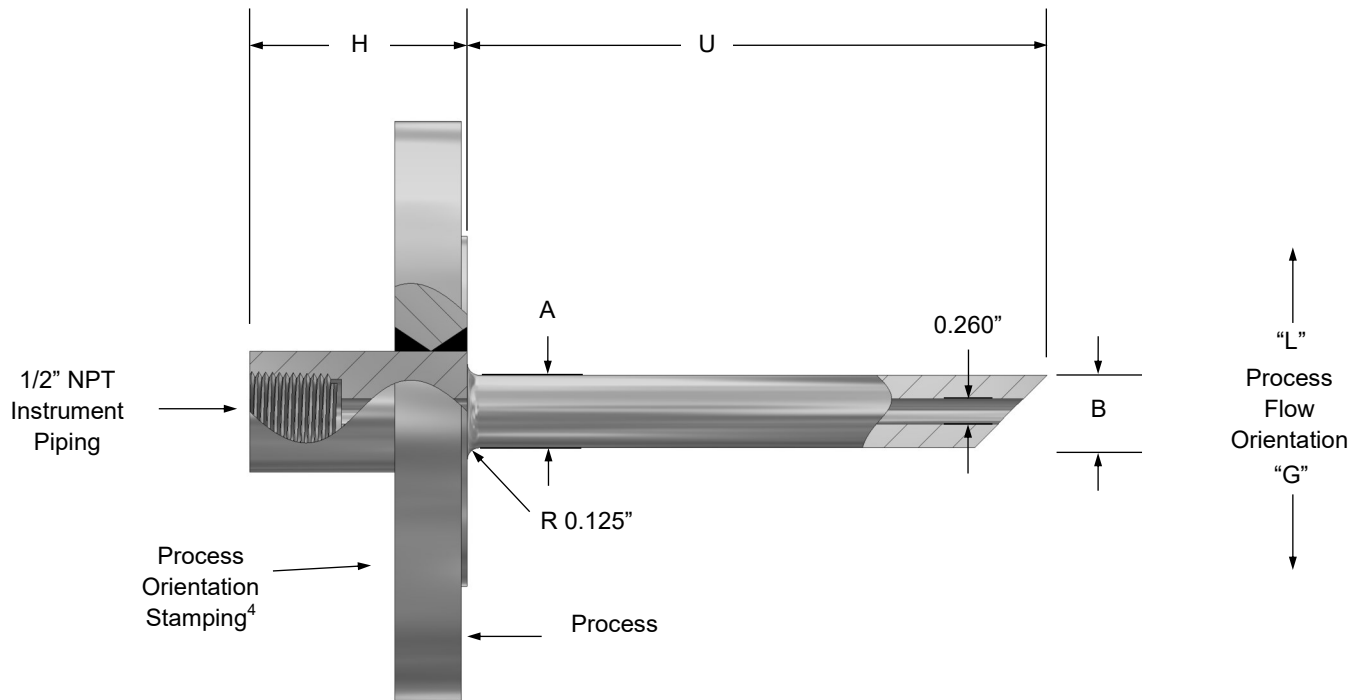

NOTES:

1. Bar stock to flange is a full penetration weld
2. Flange dimensions per ASME B16.5
3. Raised face (RF) flange finish 125-250 RMS
4. Quill orientation to process flow will be stamped with an arrow on flange
5. Quill opening (T8) 45° shown
6. Quill bolt orientation to be two-hole
7. "RF" raised face flange face (T4) shown above