

# F327 Straight Flanged Quill Model Code

F327 - T1 - T2 T3 T4 T5 - T6 - T7 - T8 - T9 - T10

## F327 Straight - 0.385" Bore - Flanged - Quill

### T1 Quill Stem Material

304	304/304L stainless	F11	F11
<b>316</b>	<b>316/316L stainless</b>	F44	Alloy 254
310	310 stainless steel	F51	Duplex 2205
600	Inconel 600	HAC	Hastelloy C276
625	Inconel 625	HAB	Hastelloy B
800	Incoloy 800	LF2	A350 LF2
825	Incoloy 825	M40	Monel 400
8HT	Incoloy 800 HT	Ti2	Titanium Grade 2
A20	Alloy 20	Other <sup>2</sup> Consult factory	
F9	F9		

### T2 Flange Size NPS Nominal Pipe OD

1"	1" NPS	1.315"
1.5"	1.5" NPS	1.900"
2"	2" NPS	2.375"
Other	Consult factory	

### T3 Flange Class per ASME B16.5

150#	Class 150
300#	Class 300
600#	Class 600
900#	Class 900
1500#	Class 1500
2500#	Class 2500

### T4 Flange Face

<b>RF</b>	<b>Raised face</b>
RTJ	Ring-type joint
FF	Flat face

### T5 Quill Flange Material

304	304/304L stainless	F11	F11
<b>316</b>	<b>316/316L stainless</b>	F44	Alloy 254
310	310 stainless steel	F51	Duplex 2205
600	Inconel 600	HAC	Hastelloy C276
625	Inconel 625	HAB	Hastelloy B
800	Incoloy 800	LF2	A350 LF2
825	Incoloy 825	M40	Monel 400
8HT	Incoloy 800 HT	Ti2	Titanium Grade 2
A20	Alloy 20	Other <sup>2</sup> Consult factory	
F9	F9		

### T6 Specify "U" Dimension (inches)<sup>3</sup>

"inches"	Specify length in inches
----------	--------------------------

### T7 Specify "H" Head Length (inches)<sup>3</sup>

2.25	2.25" standard minimum for class 150#, 300#, 600#
3.25	3.25" standard minimum for class 900#, 1500# 2500#
Other	Specify length in inches

### T8 Specify "A" & "B" (Shank) Diameter<sup>4</sup>

0.625	0.625" (minimum)
<b>0.75</b>	<b>0.75" (standard)</b>
<b>1.00</b>	<b>1.00"</b>
1.125	1.125"
1.250	1.250"
1.5	1.5"
Other	Specify diameter in inches

### T9 Quill Opening

45	45° Angle
90	90° Angle (straight)
HD	Holes along shank <sup>5</sup>

### T10 Process Flow Orientation

G	Into back wall of pipe
L	Into 45° or holes along shank

#### NOTES:

1. Part number example: F327-316-2"600#RF316-10-2.25-1.063-0.75-45-L
2. Canadian Registration Number (CRN) available for most common alloys, consult factory
3. Reference page 2 for part outline and dimensions
4. Maximum allowable shank diameter must be less than the nominal pipe OD (T2)
5. Specify number of holes, size and locations
6. Bold text indicates most common part selections



# F327 Flanged Quill Outline & Dimensions

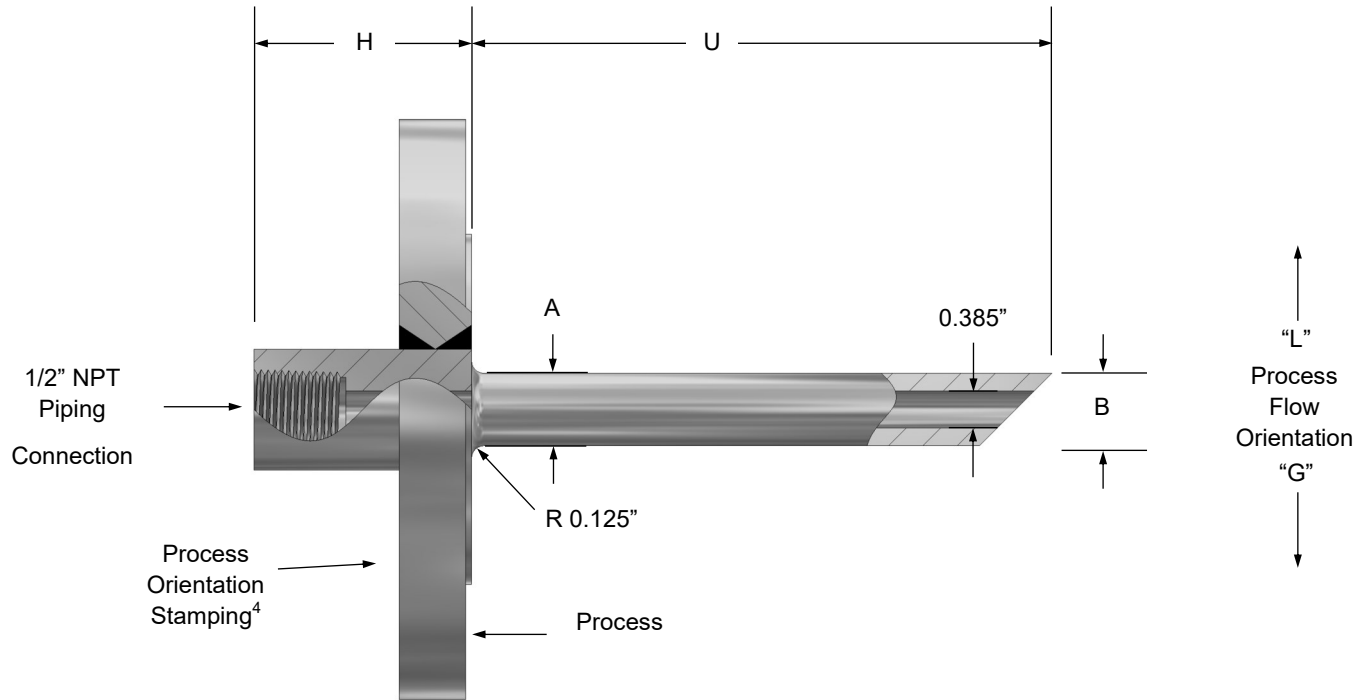

## NOTES:

1. Bar stock to flange is a full penetration weld
2. Flange dimensions per ASME B16.5
3. Raised face (RF) flange finish 125-250 RMS
4. Quill orientation to process flow will be stamped with an arrow on flange
5. Quill opening (T8) 45° shown
6. Quill bolt orientation to be two-hole
7. "RF" raised face flange face (T4) shown above