

AQ04A Pipe Quill Model Code

AQ04A - T1 - T2 - T3 - T4 T5 - T6 - T7 - T8 - T9

AQ04A Pipe Quill - RF Slip-On Flange by Ball Valve

T1	Quill Pipe Size NPS	Pipe OD	Pipe ID
AA	1/2" SCH 80	0.840"	0.546"
BA	3/4" SCH 80	1.050"	0.742"
CA	1" SCH 80	1.315"	0.957"
AB	1/2" SCH 160	0.840"	0.446"
BB	3/4" SCH 160	1.050"	0.614"
CB	1" SCH 160	1.315"	0.815"
DB	1-1/4" SCH 160	1.660"	1.160"
Other	Consult factory		

T2	Ball Valve
"model"	Specify ball valve model code with no symbols

T3	Process Connection Flange Size ² NPS
1/2"	1/2" NPS
3/4"	3/4" NPS
1"	1" NPS
1.25"	1-1/4" NPS
1.5"	1-1/2" NPS
2"	2" NPS
3"	3" NPS
4"	4" NPS

T4	Process Connection Flange Class ASME B16.5
150#RF	Class 150 raised face flange
300#RF	Class 300 raised face flange
600#RF	Class 600 raised face flange
900#RF	Class 900 raised face flange
1500#RF	Class 1500 raised face flange

T5	Quill Material
316	316/316L stainless
HAC	Hastelloy C276
LF2	A350 LF2

Other³ Consult factory

T6	Specify Quill "U" Length (inches) ⁴
"inches"	Specify length in inches

T7	Specify Quill "A" Length (inches) ⁴
"inches"	Specify length in inches (minimum 3")

T8	Quill Opening
45	45° Angle
90	90° Angle (straight)
HD	Holes along pipe ⁵

T9	Process Flow Orientation
G	Into back wall of pipe
L	Into 45° or HD

NOTES:

1. Part number example: AQ04A-BA-5AT3R07TS30SZ3-2"300#RF-LF2-12-4-45-L
2. Flange size can not be smaller than (T1) Quill Pipe Size NPS
3. Canadian Registration Number (CRN) available for some common alloys, consult factory
4. Reference page 2 for part outline and dimensions
5. Specify number of holes, size and locations
6. Bold text indicates most common part selections



AQ04A Pipe Quill Outline & Dimensions

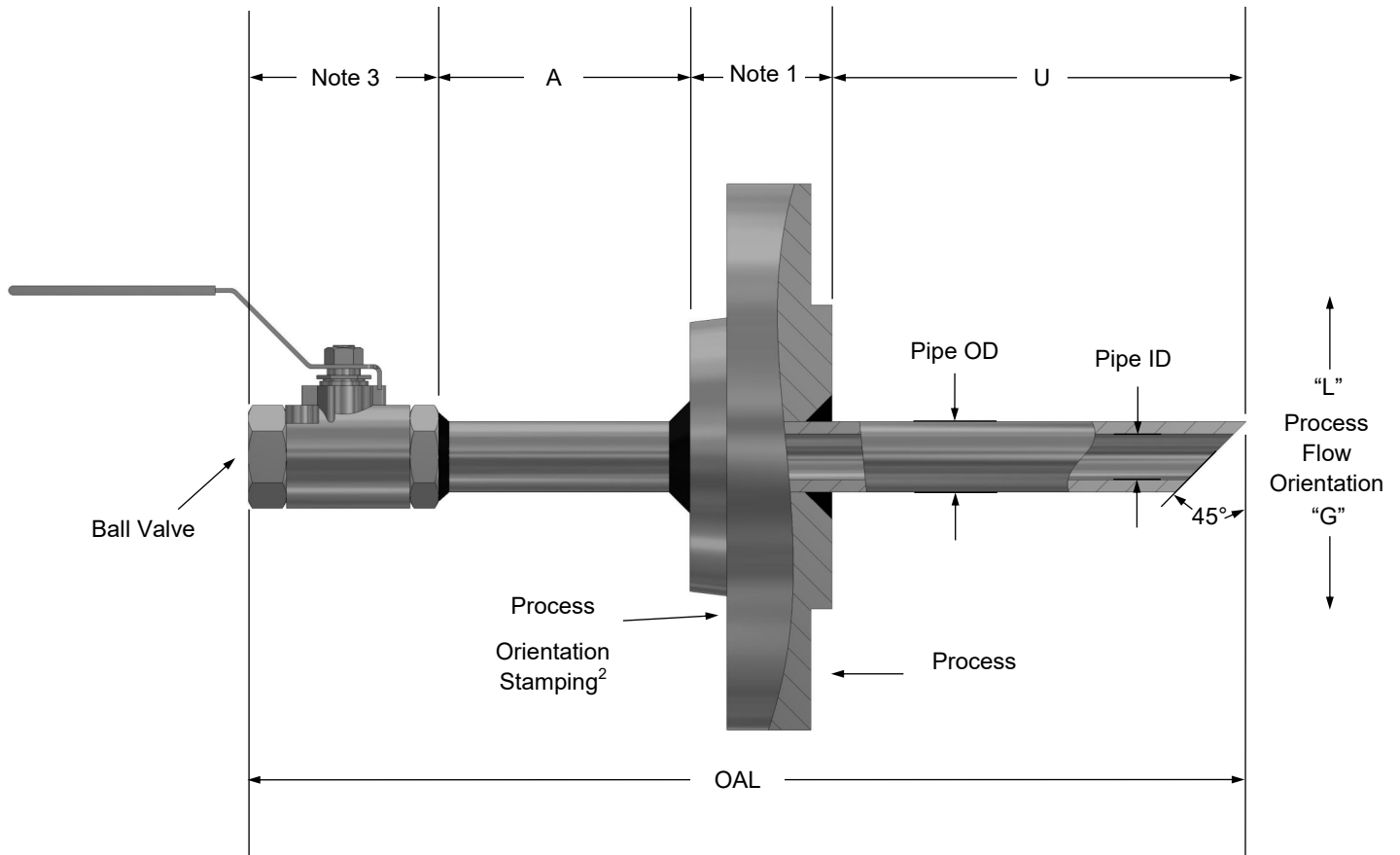

NOTES:

1. Flange dimensions per ASME B16.5, coupling dimensions per ASME B16.11
2. Quill orientation to process flow will be stamped with an arrow on flange face
3. Valve dimensions per manufacturers specifications
4. Quill bolt Orientation to be two-hole
5. Quill opening (T7) 45° shown

