

SW227 Socket Weld 0.260" Bore Quill

Model Code

SW227 - T1 - T2 - T3 - T4

SW227 Straight - 0.260" Bore - Socket Weld - Quill

T1	Process Connection	Nominal Pipe OD
3/4	3/4" NPS	1.050"
1	1" NPS	1.315"
Other Consult factory		

T2	Rating
3	3000#
6	6000#

T3	Material
304	304/304L stainless 800 Incoloy 800
316	316/316L stainless F51 Duplex 2205
310	310 stainless steel LF2 A350 LF2
600	Inconel 600 HAC Hastelloy C276
625	Inconel 625 Other ² Consult factory

T4	Specify "U" Length (inches)
"inches"	Specify length in inches

Outline & Dimensions

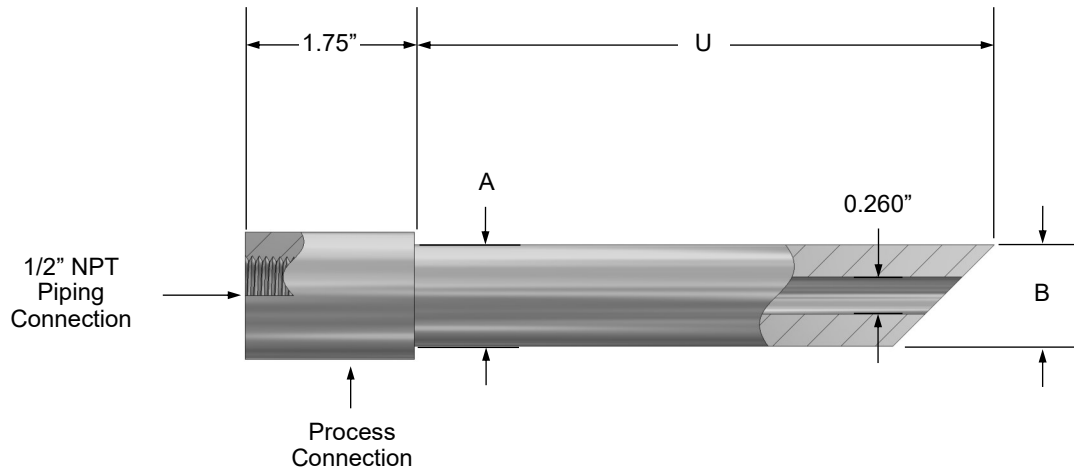

Process Connection	"A" & "B" (OD)	
	3000#	6000#
3/4" NPS	0.750"	0.609"
1" NPS	0.750"	0.750"

NOTES:

1. Part number example: SW227-3/4-3-316-6
2. Canadian Registration Number (CRN) available for most common alloys, consult factory