

# S227 Straight 0.260" Bore Quill

## Model Code

S227 - T1 - T2 - T3

### S227 Straight - 0.260" Bore - Threaded Quill

T1	Process Connection	"A" (Root)	"B" (Tip)
1/2	1/2" NPT	0.500"	0.500"
3/4	3/4" NPT	0.750"	0.750"
1	1" NPT	0.750"	0.750"

T2	Material		
304	304/304L stainless	800	Incoloy 800
316	316/316L stainless	F51	Duplex 2205
310	310 stainless steel	LF2	A350 LF2
600	Inconel 600	HAC	Hastelloy C276
625	Inconel 625	Other <sup>2</sup>	Consult factory

T3	Specify "U" Length (inches)
"inches"	Specify length in inches

## Outline & Dimensions

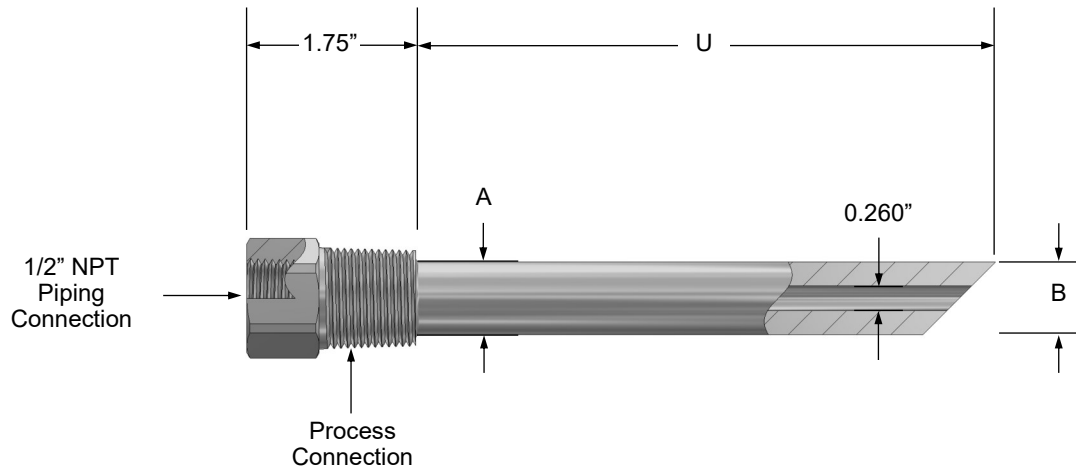

### NOTES:

1. Part number example: S227-1/2-316-3
2. Canadian Registration Number (CRN) available for most common alloys, consult factory