

AQ76 Flanged Sample Quill Model Code

AQ76 - T1 T2 T3 - T4 - T5

AQ76	Sample Quill - 0.385" Bore - Flanged to Process	
Needle Valve /w Threaded Vent Port - 316/316L		

T1	Flange Size NPS	Nominal Pipe OD
1"	1" NPS	1.315"
1.5"	1.5" NPS	1.900"
2"	2" NPS	2.375"
Other	Consult factory	

T2	Flange Class per ASME B16.5
150#	Class 150
300#	Class 300
600#	Class 600
900#	Class 900
1500#	Class 1500
2500#	Class 2500

T3	Flange Face
RF	Raised face
RTJ	Ring-type joint
FF	Flat face

T4	Specify "U" Length (inches)
"inches"	Specify length in inches

T5	Process Flow Orientation
G	Into back wall of shank
L	Into 45°

Needle Valve with vent Specifications	
Valve configuration	Needle (isolation)
Piping connection	1/2" NPT(F)
Seat diameter	5mm
Vent port	1/4" NPT(F) port (plugged)
Wetted material & body	316/316L Stainless Steel
Packing material	PTFE (-35 to 204°C)
Pressure / temperature rating	6000psi @ 100°F (38°C) / 1015 psi @ 400°F (204°C)
Valve design	B16.5, B16.34
Valve manufacturer	Mac-Weld Machining Ltd.

NOTES:

1. Part number example: AQ76-2"300#RF-12-G
2. Quill, nipple and valve material is 316/316L stainless steel
3. Reference page 2 for part outline and dimensions
4. Consult factory for Canadian Registration Number (CRN) information



AQ76 Flanged Quill Outline & Dimensions

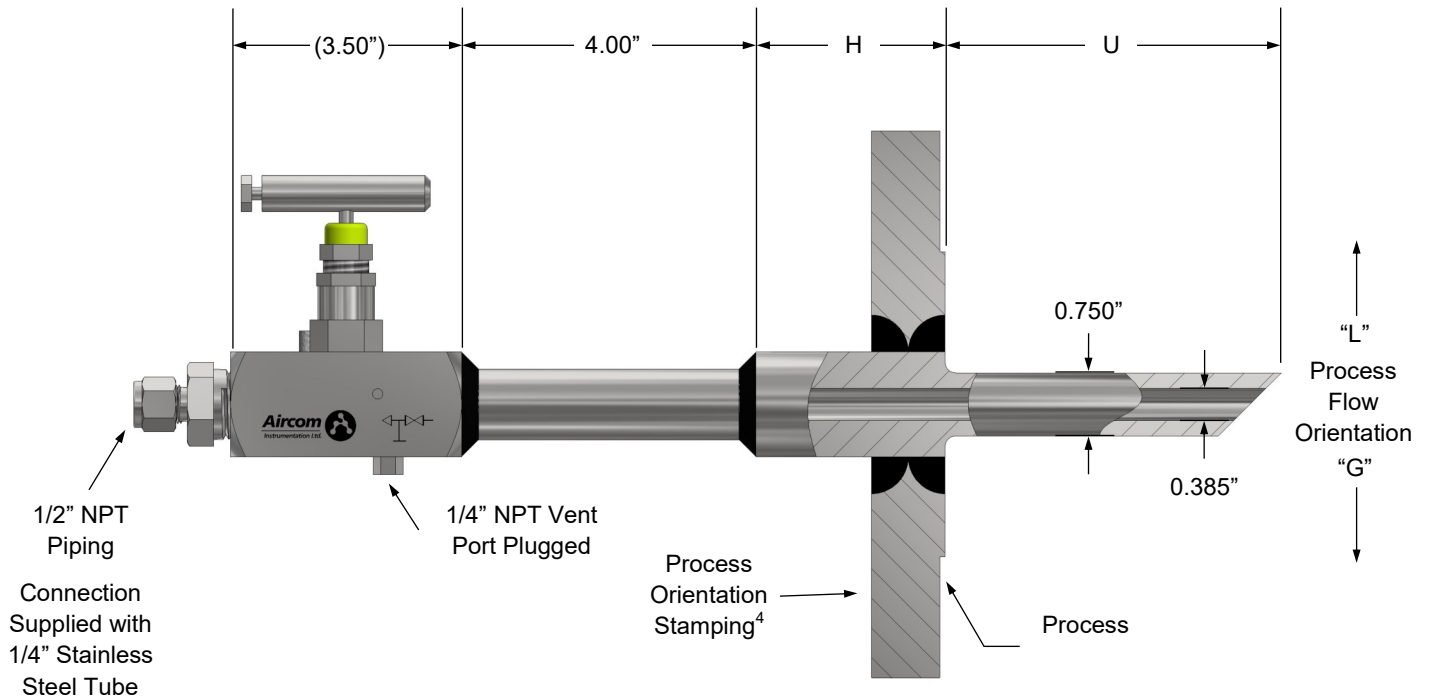

Aircom Standard "H" Length (inches)					
Class 150	Class 300	Class 600	Class 900	Class 1500	Class 2500
2.25"	2.25"	2.25"	3.25"	3.25"	3.25"

NOTES:

1. Bar stock to flange is a full penetration weld
2. Flange dimensions per ASME B16.5
3. Raised face (RF) flange finish 125-250 RMS
4. Quill orientation to process flow will be stamped with an arrow on flange face
5. Quill bolt orientation to be two-hole
6. "RF" raised face flange face (T3) shown above

