

# F26 Stepped Flanged Thermowell Model Code

F26 - T1 - T2 T3 T4 T5 - T6 - T7

## F26 Stepped - 0.260" Bore - Flanged

### T1 Thermowell Stem Material

304	304/304L stainless	F11	F11
<b>316</b>	<b>316/316L stainless</b>	F44	Alloy 254
310	310 stainless steel	F51	Duplex 2205
600	Inconel 600	HAC	Hastelloy C276
625	Inconel 625	HAB	Hastelloy B
800	Incoloy 800	LF2	A350 LF2
825	Incoloy 825	M40	Monel 400
8HT	Incoloy 800 HT	TI2	Titanium Grade 2
A20	Alloy 20	Other <sup>2</sup> Consult factory	
F9	F9		

### T2 Process Connection Nominal Pipe OD

1"	1" NPS	1.315"
1.5"	1.5" NPS	1.900"
2"	2" NPS	2.375"
Other	Consult factory	

### T3 Flange Class per ASME B16.5

150#	Class 150
300#	Class 300
600#	Class 600
900#	Class 900
1500#	Class 1500
2500#	Class 2500

## T4 Flange Face

<b>RF</b>	<b>Raised face</b>
RTJ	Ring-type joint
FF	Flat face

## T5 Thermowell Flange Material

304	304/304L stainless	F11	F11
<b>316</b>	<b>316/316L stainless</b>	F44	Alloy 254
310	310 stainless steel	F51	Duplex 2205
600	Inconel 600	HAC	Hastelloy C276
625	Inconel 625	HAB	Hastelloy B
800	Incoloy 800	LF2	A350 LF2
825	Incoloy 825	M40	Monel 400
8HT	Incoloy 800 HT	TI2	Titanium Grade 2
A20	Alloy 20	Other <sup>2</sup> Consult factory	
F9	F9		

## T6 Specify "U" Length (inches)<sup>3</sup>

"inches"	Specify length in inches
----------	--------------------------

## T7 Specify "H" Head Length (inches)<sup>3</sup>

2.25	2.25" standard minimum for class 150#, 300#, 600#
3.25	3.25" standard minimum for class 900#, 1500# 2500#
Other	Specify length in inches

### Special option codes specified as come complete with (c/w) thermowell if required

Code	Description
SSPC	Stainless steel plug and chain
BRPC	Brass plug and chain
OVRL	Overlay (details to be specified)

### NOTES:

1. Part number example: F26-316-2"150#RF316-7-2.25 or F26-316-2"300#RF316-10.25-2.25 c/w SSPC
2. Canadian Registration Number (CRN) available for most common alloys, consult factory
3. Reference page 2 for part outline and dimensions
4. Bold text indicates most common part selections



# F26 Flanged Thermowell Outline & Dimensions

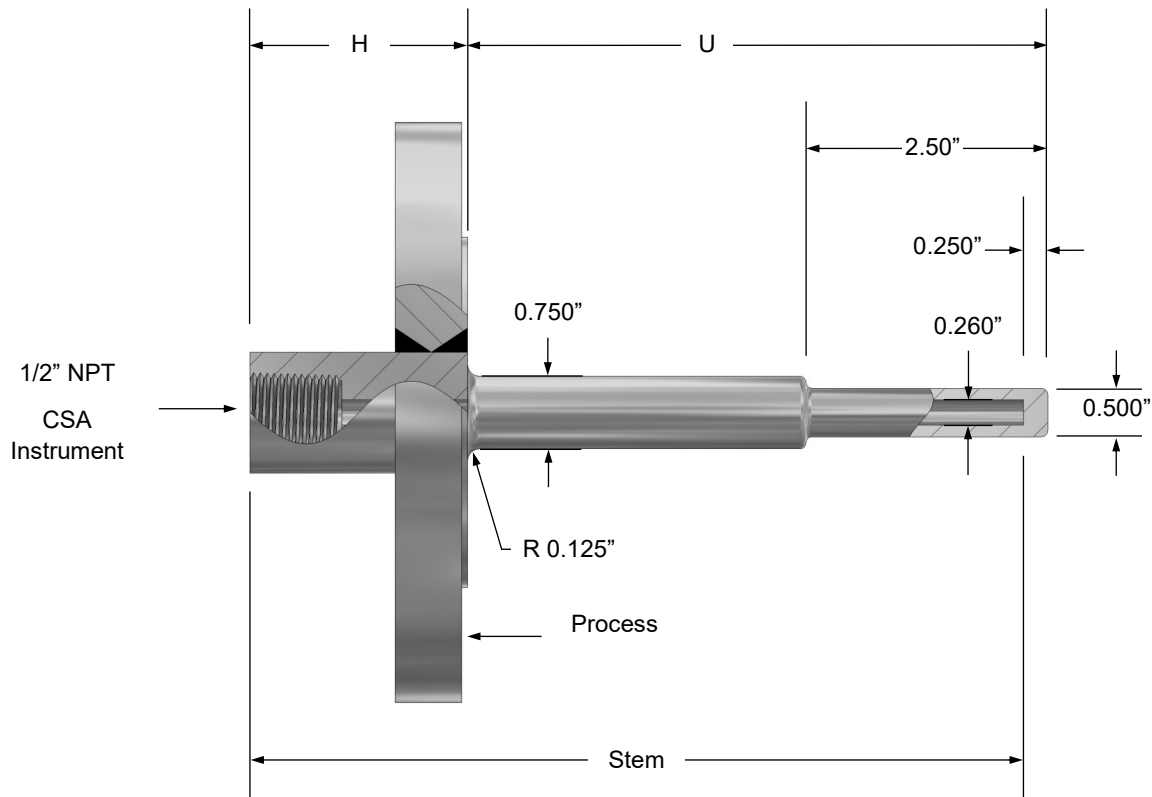

## NOTES:

1. Bar stock to flange is a full penetration weld
2. Flange dimensions per ASME B16.5
3. Raised face (RF) flange finish 125-250 RMS, for other consult factory
4. "RF" raised face flange face (T4) shown above

