

F22 Straight Flanged Thermowell Model Code

F22 - T1 - T2 T3 T4 T5 - T6 - T7 - T8

F22 Straight - 0.260" Bore - Flanged

T1 Thermowell Stem Material

304	304/304L stainless	F11	F11
316	316/316L stainless	F44	Alloy 254
310	310 stainless steel	F51	Duplex 2205
600	Inconel 600	HAC	Hastelloy C276
625	Inconel 625	HAB	Hastelloy B
800	Incoloy 800	LF2	A350 LF2
825	Incoloy 825	M40	Monel 400
8HT	Incoloy 800 HT	TI2	Titanium Grade 2
A20	Alloy 20	Other ² Consult factory	
F9	F9	Other ² Consult factory	

T2 Process Connection Nominal Pipe OD

1"	1" NPS	1.315"
1.5"	1.5" NPS	1.900"
2"	2" NPS	2.375"
Other	Consult factory	

T3 Flange Class per ASME B16.5

150#	Class 150
300#	Class 300
600#	Class 600
900#	Class 900
1500#	Class 1500
2500#	Class 2500

T4 Flange Face

RF	Raised face
RTJ	Ring-type joint
FF	Flat face

T5 Thermowell Flange Material

304	304/304L stainless	F11	F11
316	316/316L stainless	F44	Alloy 254
310	310 stainless steel	F51	Duplex 2205
600	Inconel 600	HAC	Hastelloy C276
625	Inconel 625	HAB	Hastelloy B
800	Incoloy 800	LF2	A350 LF2
825	Incoloy 825	M40	Monel 400
8HT	Incoloy 800 HT	TI2	Titanium Grade 2
A20	Alloy 20	Other ² Consult factory	
F9	F9	Other ² Consult factory	

T6 Specify "U" Length (inches)³

"inches"	Specify length in inches
----------	--------------------------

T7 Specify "H" Head Length (inches)³

2.25	2.25" standard minimum for class 150#, 300#, 600#
3.25	3.25" standard minimum for class 900#, 1500# 2500#
Other	Specify length in inches

T8 Specify "A" & "B" (Shank) Diameter⁴

0.50	0.5" (minimum)
0.625	0.625"
0.75	0.75" (standard)
1.00	1.00"
1.125	1.125"
1.250	1.250"
1.5	1.5"
Other	Specify outside diameter in inches

Special option codes specified as come complete with (c/w) thermowell if required

Code	Description
SSPC	Stainless steel plug and chain
BRPC	Brass plug and chain
OVRL	Overlay (details to be specified)

NOTES:

1. Part number example: F22-316-2"600#RF316-12-2.25-0.75 or F22-625-1.5"900#RF625-10-3.25-1.00
2. Canadian Registration Number (CRN) available for most common alloys, consult factory
3. Reference page 2 for part outline and dimensions
4. Maximum allowable shank diameter must be less than the nominal pipe OD (T2)
5. Bold text indicates most common part selections



F22 Flanged Thermowell Outline & Dimensions

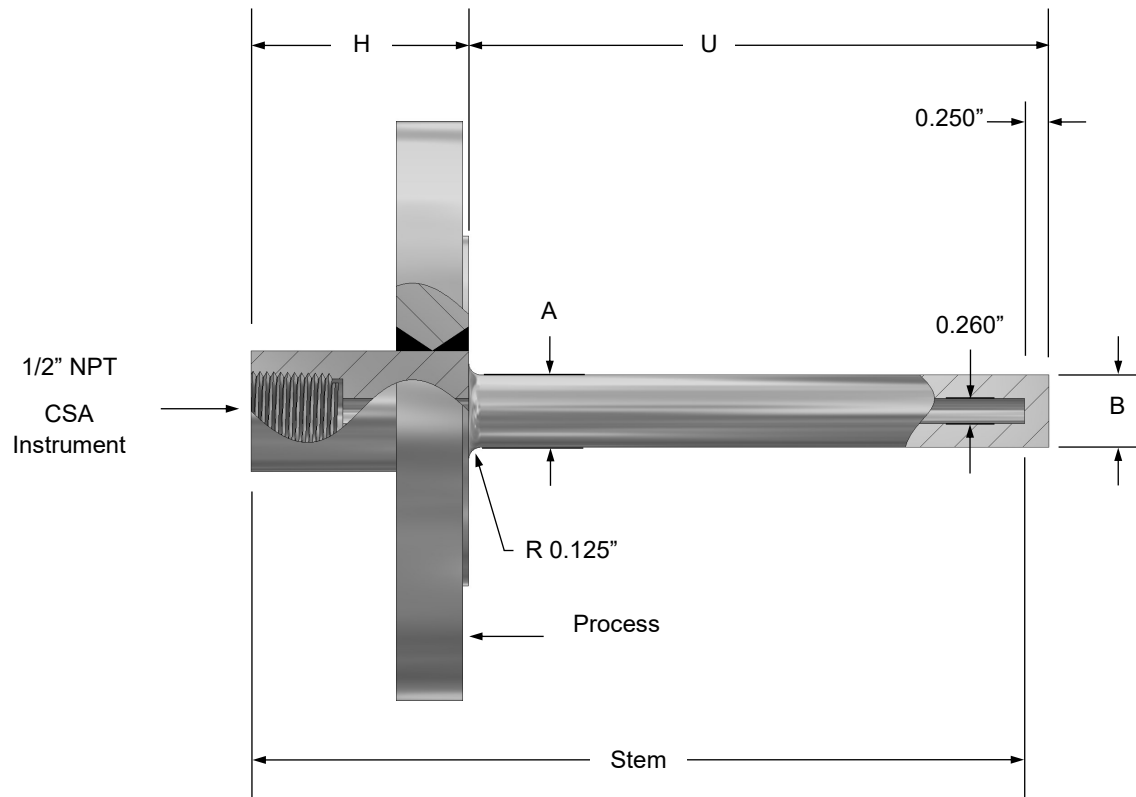

NOTES:

1. Bar stock to flange is a full penetration weld
2. Flange dimensions per ASME B16.5
3. Raised face (RF) flange finish 125-250 RMS, for other consult factory
4. "RF" raised face flange face (T4) shown above

