

SW32 Socket Weld 0.385" Bore Thermowell

Model Code

SW32 - T1 - T2 - T3 - T4

SW32 Straight - 0.385" Bore - Socket Weld

T1	Process Connection	Nominal Pipe OD
3/4	3/4" NPS	1.050"
1	1" NPS	1.315"
Other	Consult factory	

T2	Rating
3	Class 3000
6	Class 6000

T3	Material
304	304/304L stainless 800 Incoloy 800
316	316/316L stainless F51 Duplex 2205
310	310 stainless steel LF2 A350 LF2
600	Inconel 600 HAC Hastelloy C276
625	Inconel 625 Other ³ Consult factory

T4	Specify "U" Length (inches)
"inches"	Specify length in inches

Outline & Dimensions

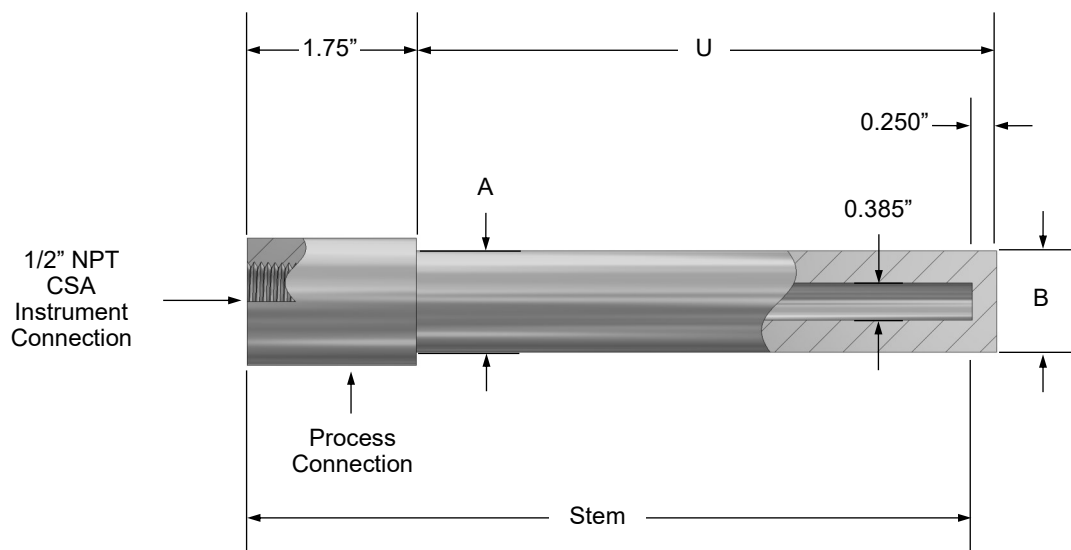

Process Connection	"A" & "B" OD	
	CL 3000	CL 6000
3/4" NPS	0.750"	NA
1" NPS	0.750"	0.750"

Special option codes specified as come complete with (c/w) thermowell if required

Code	Description
SSPC	Stainless steel plug and chain
BRPC	Brass plug and chain
OVRL	Overlay (details to be specified)

NOTES:

- Part number example: SW32-1-3-316-5 or SW32-3/4-6-316-7.5 c/w SSPC
- Canadian Registration Number (CRN) available for most common alloys, consult factory

