

# WF34 Tapered 0.385" Bore Thermowell

## Model Code

WF34 - T1 - T2 - T3

### WF34 Tapered - 0.385" Bore - Wrench Flat - Threaded

| T1    | Process Connection | "A" (Root) | "B" (Tip) |
|-------|--------------------|------------|-----------|
| 3/4   | 3/4" NPT           | 0.875"     | 0.750"    |
| 1     | 1" NPT             | 1.063"     | 0.750"    |
| Other | Consult factory    |            |           |

| T2  | Material            |                    |                 |
|-----|---------------------|--------------------|-----------------|
| 304 | 304/304L stainless  | 800                | Incoloy 800     |
| 316 | 316/316L stainless  | F51                | Duplex 2205     |
| 310 | 310 stainless steel | LF2                | A350 LF2        |
| 600 | Inconel 600         | HAC                | Hastelloy C276  |
| 625 | Inconel 625         | Other <sup>2</sup> | Consult factory |

| T3       | Specify "U" Length (inches) |
|----------|-----------------------------|
| "inches" | Specify length in inches    |

## Outline & Dimensions

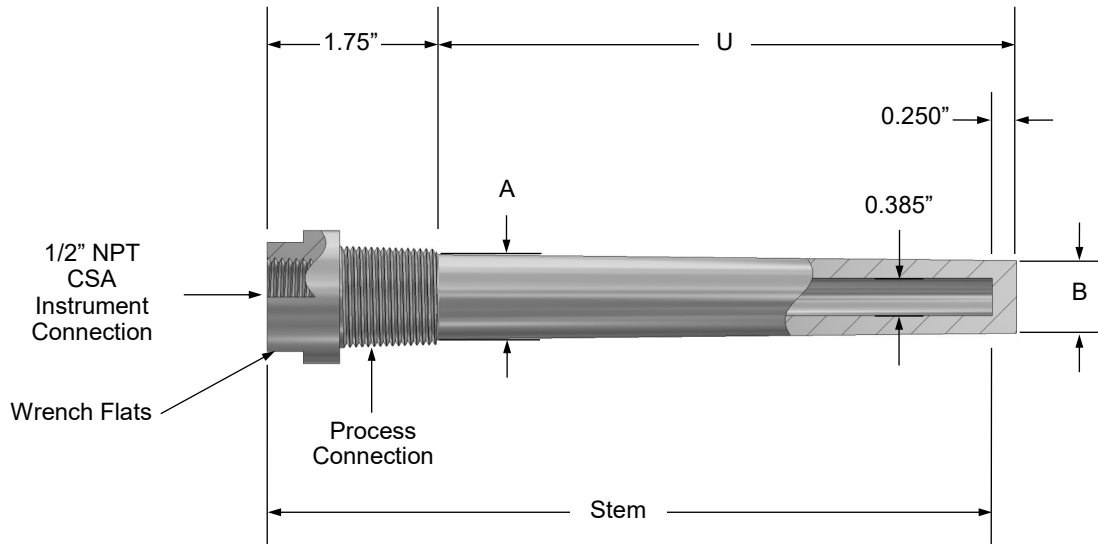

### Special option codes specified as come complete with (c/w) thermowell if required

| Code | Description                       |
|------|-----------------------------------|
| SSPC | Stainless steel plug and chain    |
| BRPC | Brass plug and chain              |
| OVRL | Overlay (details to be specified) |

### NOTES:

1. Part number example: WF34-1-316-4.5 or WF34-3/4-316-2.5 c/w SSPC
2. Canadian Registration Number (CRN) available for most common alloys, consult factory

